

How to Identify the Boiler Type and Model

1 - Purpose

This document explains how to identify your boiler type and model in the scope of the **2025 voluntary recall** launched by Triangle Tube.

2 - What does your boiler look like?

Click on the image corresponding to your boiler to reach the model identification page

OR

click on the link in the text below the boiler.

If it looks like this,
it **IS NOT PART** of the
2025 voluntary recall.

No further action
is required

If it looks like this,
it **IS PART** of the
2025 voluntary recall

[Go to page 2](#)

If it looks like this,
it **MAY BE PART** of the
2025 voluntary recall

[Go to page 8](#)

HOW TO IDENTIFY THE BOILER TYPE AND MODEL

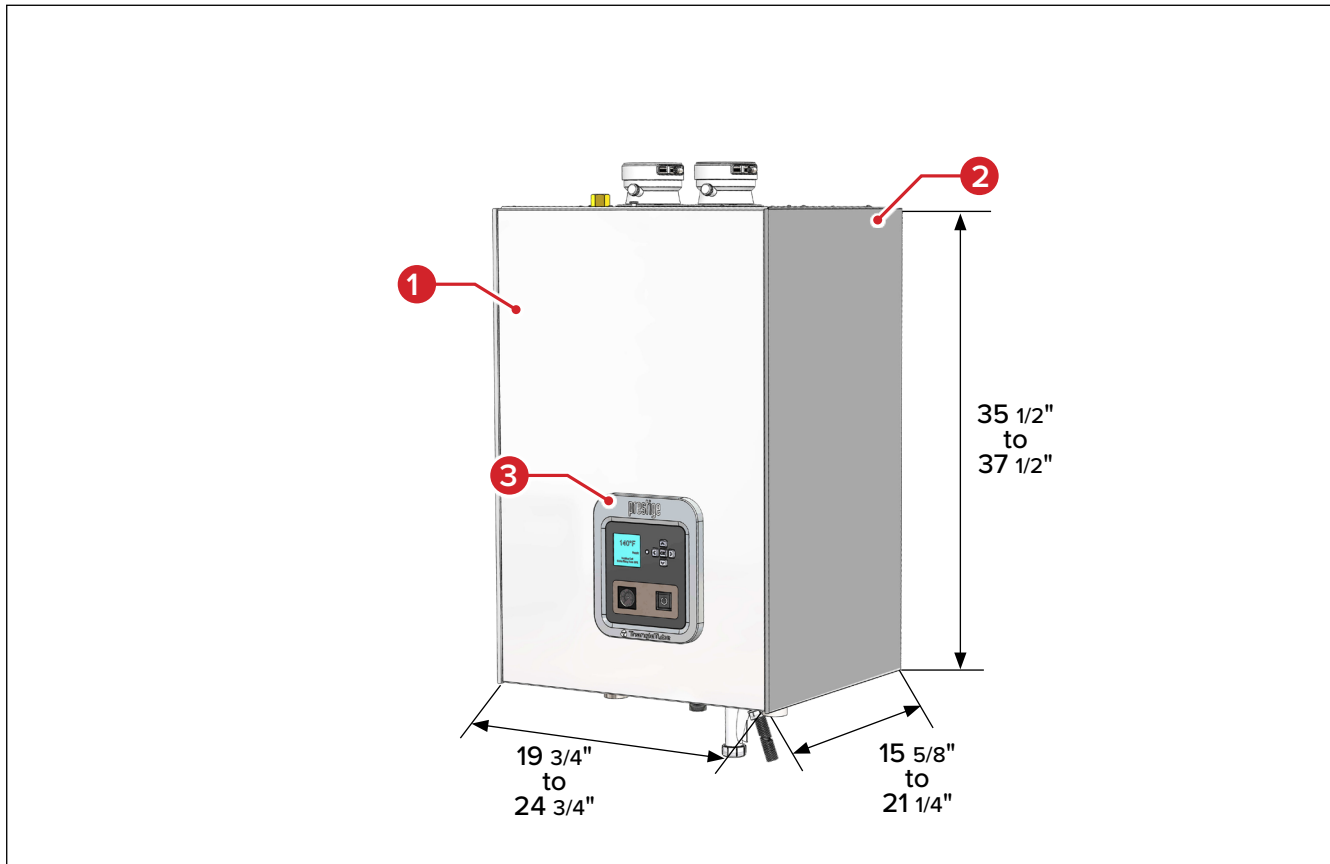

You have a boiler that looks like this

It was **produced between 2011 and 2015** and has the following characteristics :

Overall dimensions : 2 sizes of cabinet.

1. White front panel
2. Grey side panels
3. Square grey control panel.



- ◆ it is a **Triangle Tube PT- prefixed** boiler if the control panel looks like this (Prestige written at the top and Triangle Tube logo at the bottom)

Triangle Tube



Your boiler is subjected to the 2025 voluntary recall program.

Go to [page 4](#) to identify the model.

- ◆ it is an **Aerco Esteem 399** boiler if the control panel looks like this and there is either this logo  or this logo  at the top of the white front panel :

AERCO
A WATTS Brand



Your boiler is subjected to the 2025 voluntary recall program.

Go to [page 3](#) to know what to do.

HOW TO IDENTIFY THE BOILER TYPE AND MODEL

3 - What to do if you have an Aerco Esteem Boiler



To identify correctly your appliance and determine the tasks to be performed in the scope of the 2025 Voluntary Recall, the Serial Number of your boiler is necessary.

1. If you have it readily available on an invoice or any other documentation related to the boiler, make note of it.
2. Connect to Triangle Tube's Customer portal, through which Triangle Tube manages customer requests in the scope of the 2025 Voluntary Recall:

On line portal via www.triangletube.com and hit the link PRODUCT RECALL INFORMATION or

Freephone **877-574-5036** from 8 a.m. to 5 p.m. ET Monday through Friday or email at productrecall@triangletube.com.

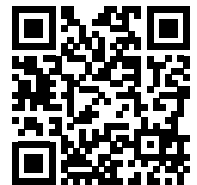

3. Alternatively, you can contact your installer or service agency and ask them to proceed with the 2025 voluntary recall on your behalf.
4. If you don't have the Serial Number, you can find it behind the front panel, which needs to be removed. See [Section 4.2 on page 5](#).

HOW TO IDENTIFY THE BOILER TYPE AND MODEL

4 - Identifying a PT- Prefixed Model

4.1 Identification with the Label under the Boiler

Most of the PT models can be identified using the black label located under the appliance.

Please check the boiler model indicated on the label and find your corresponding model in the table at the bottom of the page. Then go to [4.3 on page 7](#)

You can make note of the collected information in the form provided on [page 10](#).

NOTICE

The labels affixed under the boiler are black and look like this :

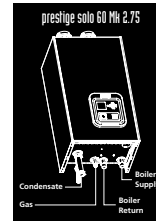

For ease of reading this document however, they are represented white with black prints.



If access is difficult, make a picture with your phone.

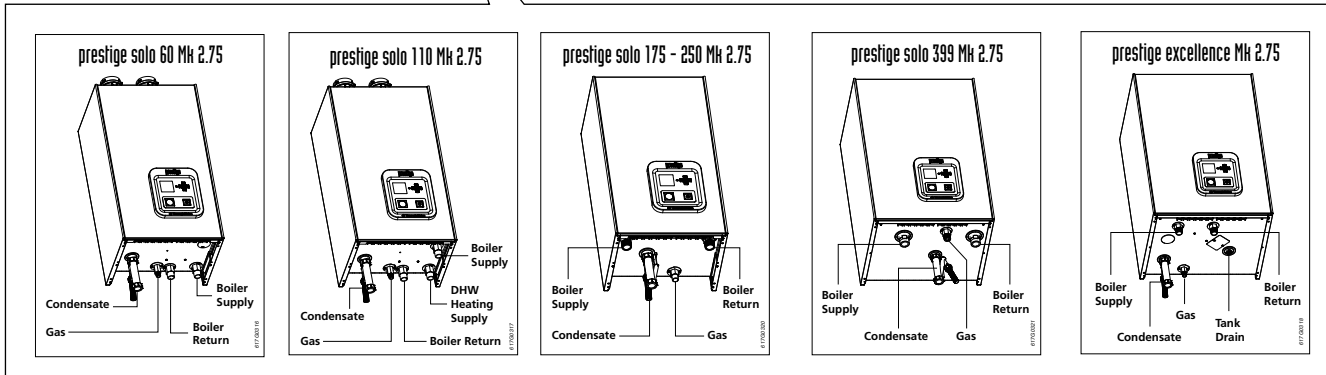
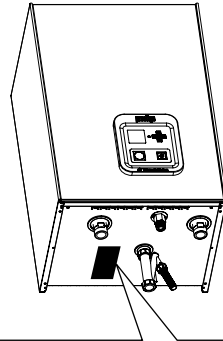

On the label	Your Model
Prestige Solo 60 MK 2.75	PT60 Solo
Prestige Solo 110 MK 2.75	PT110 Solo
Prestige Excellence 110 MK 2.75	PTE110 Excellence
Prestige Solo 399 MK 2.75	PT399 Solo
Prestige Solo 175 - 250 MK 2.75*	PT175 Solo or PT250 Solo

* See Notice opposite

NOTICE

The PT 175 and PT 250 models cannot be differentiated with this label. Therefore, to know which model you have, the front panel of the cabinet needs to be opened to see the rating label. See [Section 4.2 on page 5](#).

HOW TO IDENTIFY THE BOILER TYPE AND MODEL

4.2 Removing the Front Panel (Models 175 and 250 only and Esteem 399 boilers)

⚠ WARNING

This procedure requires the removal of a thumbscrew located at the top of the unit. Depending on the height at which the boiler is installed on the wall, a stable ladder or platform may be required for safe access.

This procedure requires lifting and handling the front panel. The front panel weighs about 9Lbs [4 kg] and is cumbersome (about 37" [95 cm] high and 24" [60 cm] wide). Before taking any action, make sure that you can handle such an item. In doubt, please call for help (a family member, a friend, a neighbor, or your boiler service company.)

⚠ WARNING

ELECTRIC SHOCK HAZARD!

Ensure power to the boiler has been switched off prior to opening the front panel of the unit.

1. Depress the main switch located at the front of the boiler to switch off. See illustration below.



2. Allow the unit to cool down for at least 15 minutes.

If you need assistance determining that your product is impacted, call Triangle Tube freephone

877-574-5036

8 a.m. to 5 p.m. ET
Monday through Friday or
contact by E-Mail:

productrecall@triangletube.com.

3. Remove the thumbscrew located on the upper edge of the unit.

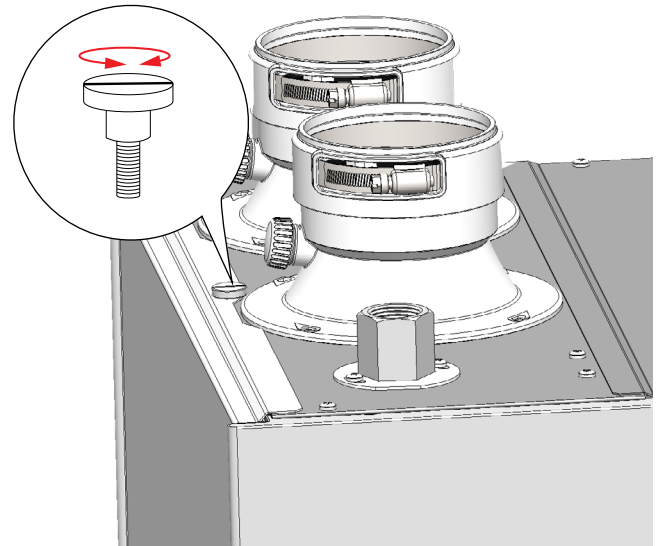

4. Holding the panel by its sides, slightly lift the panel and pull away from the unit.

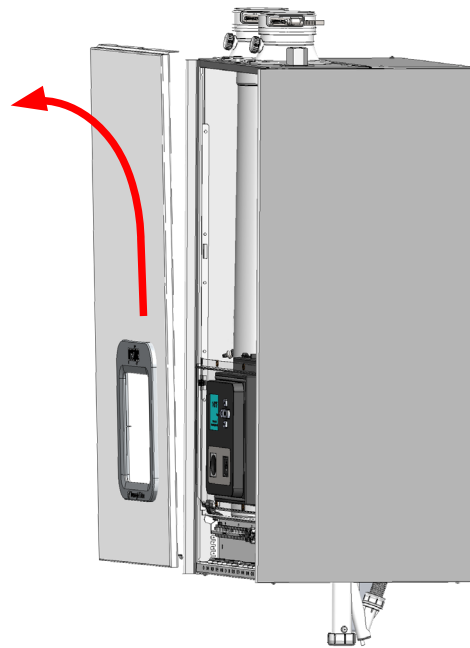

HOW TO IDENTIFY THE BOILER TYPE AND MODEL

4.2.1 Collecting the Data from the Rating Label

The rating label is located next to the control panel, inside the boiler.

What to check :

1. On the rating label, check if your model is a Prestige Solo 175 or 250 (2).
2. Collect information of Serial Number (1) and gas type (3).
3. You can make note of the collected information in the form provided on [page 10](#).



Make a picture of the rating label.

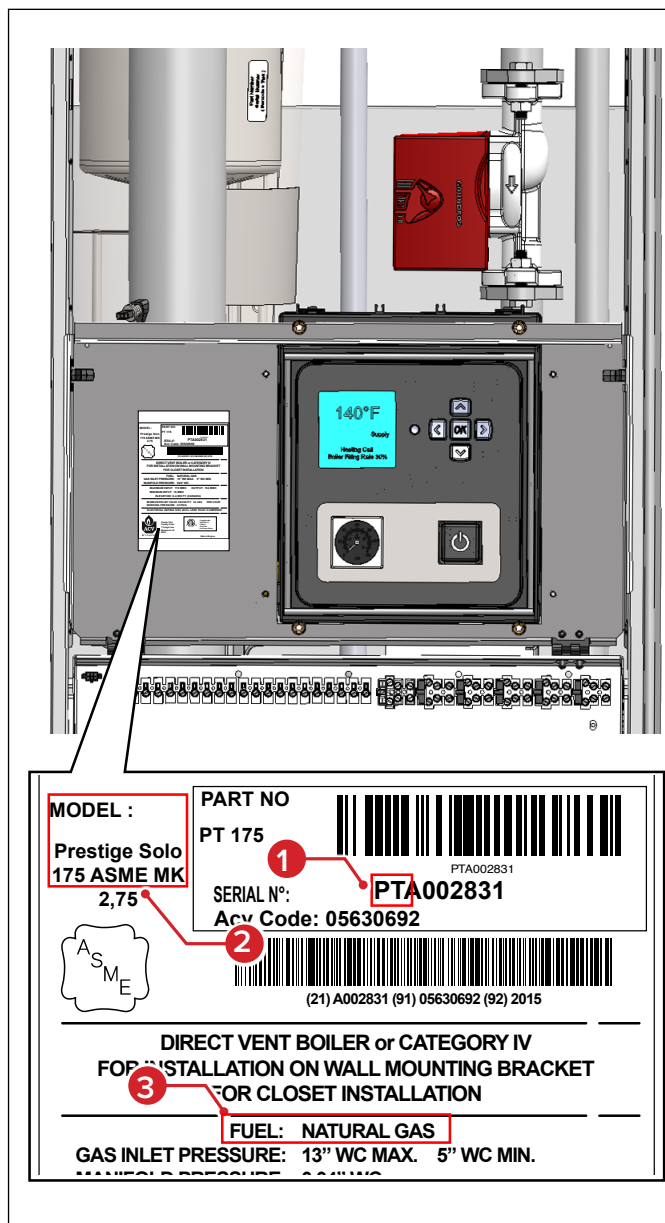
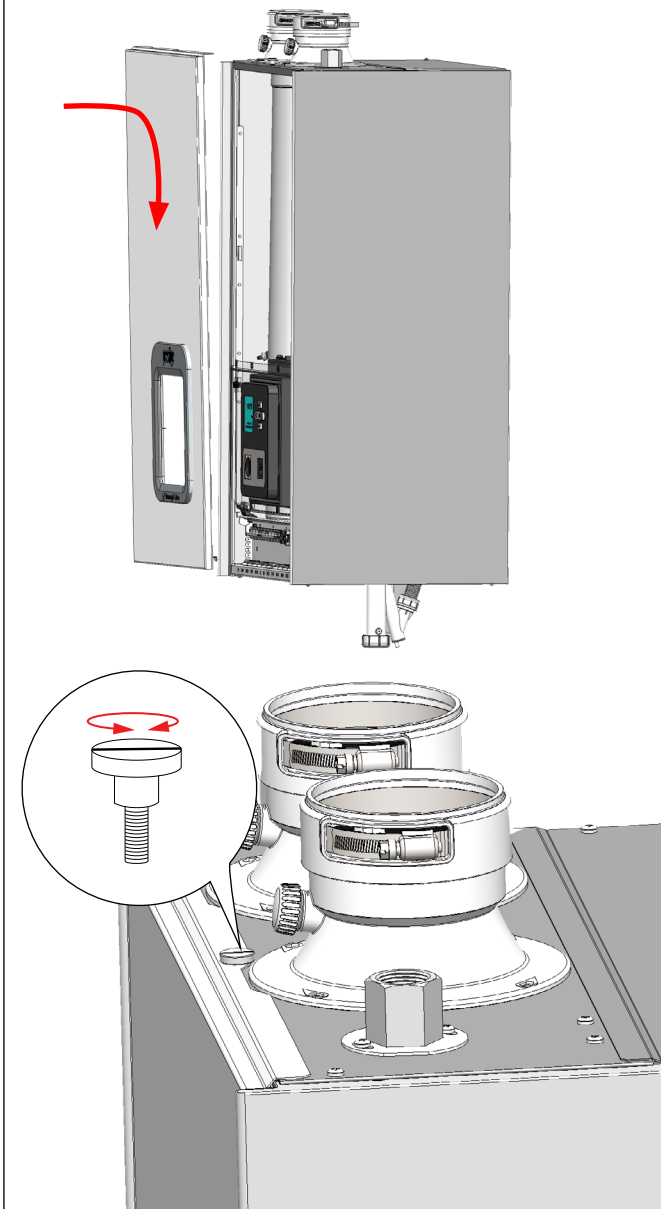

Fig. 1- Location of Rating Label and Details on PT Boilers

HOW TO IDENTIFY THE BOILER TYPE AND MODEL

4. Close the boiler front panel.



5. Restart the boiler by pushing the main switch on the control panel



4.3 Follow-on tasks (All PT models)

1. As a rule, try to find (if missing at this stage):
 - ◆ the boiler Serial Number (e.g. from an invoice or other document from your contractor)
 - ◆ the gas type used to operate the boiler (e.g. invoice from the gas company).

If you need assistance determining that your product is impacted, call **Triangle Tube** freephone

877-574-5036

8 a.m. to 5 p.m. ET
Monday through Friday or
contact by E-Mail:

productrecall@triangletube.com

2. If you managed to get the Serial Number of your appliance, you can contact Triangle Tube as indicated on [page 10](#). in order to fill in the relevant information and proceed with the 2025 voluntary recall.
3. Alternatively, you can contact your installer or service agency and ask them to proceed with the 2025 voluntary recall on your behalf.

HOW TO IDENTIFY THE BOILER TYPE AND MODEL

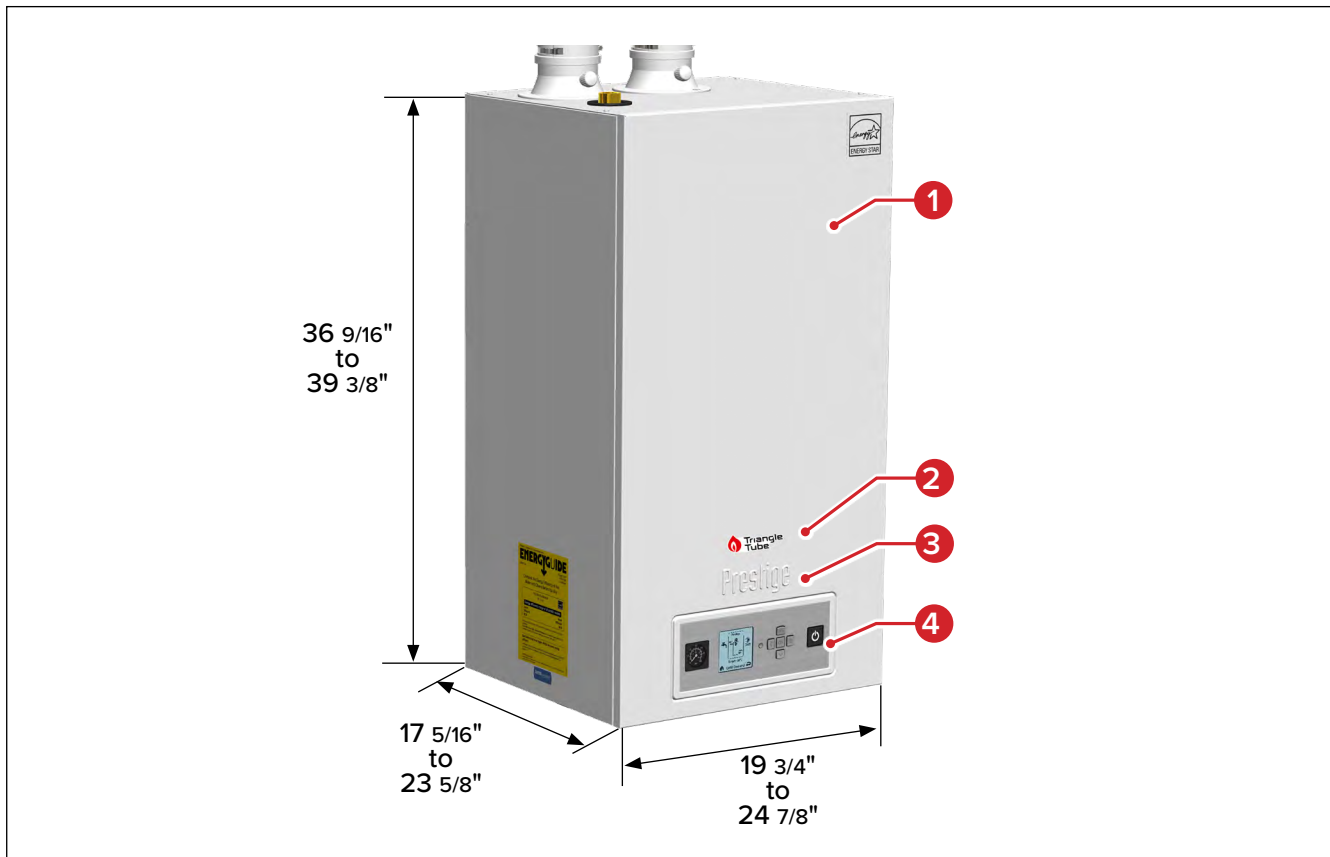

You have a Triangle Tube **PA-/PEA-** or **PB-/PEB-** prefixed Boiler if it looks like this and has the following characteristics :

Overall dimensions : 3 sizes of cabinet.

1. White casing
2. ACV (ACV) or Triangle Tube (Triangle Tube) logo at the front
3. "Prestige" name embossed on the front panel.
4. Rectangular control panel with stainless steel look.

If you have a boiler of this type, identify the model to determine if it is subjected to the 2025 voluntary recall program.

Go to [page 9](#) to identify the model.

If you need assistance determining that your product is impacted, call **Triangle Tube** freephone

877-574-5036

8 a.m. to 5 p.m. ET
Monday through Friday or
contact by E-Mail:

productrecall@triangletube.com

HOW TO IDENTIFY THE BOILER TYPE AND MODEL

5 - Identifying a PA-/PEA- prefixed Model

5.1 Rating Label

The rating label (and/or conversion rating label) is located on the right side panel of the boiler.

NOTICE

If the rating label is not readable because of insufficient clearance, try to make a picture with your phone.

What to check :

1. Check the Serial Number (3). If it starts with PB or PEB then your boiler IS NOT part of the 2025 voluntary recall.

2. Is there a PB label affixed on the Serial Number (3)? then your boiler IS NOT part of the 2025 recall, it was already part of the 2020 recall*.
3. From the rating label, collect information of model (1), Serial Number (2) and gas type (3 or 4).
4. You can note the collected information in the form provided on [page 10](#).

*For more information on the 2020 recall program, refer to the Recall page on Triangle Tube's website (<https://triangletube.com/products/product-recall>)

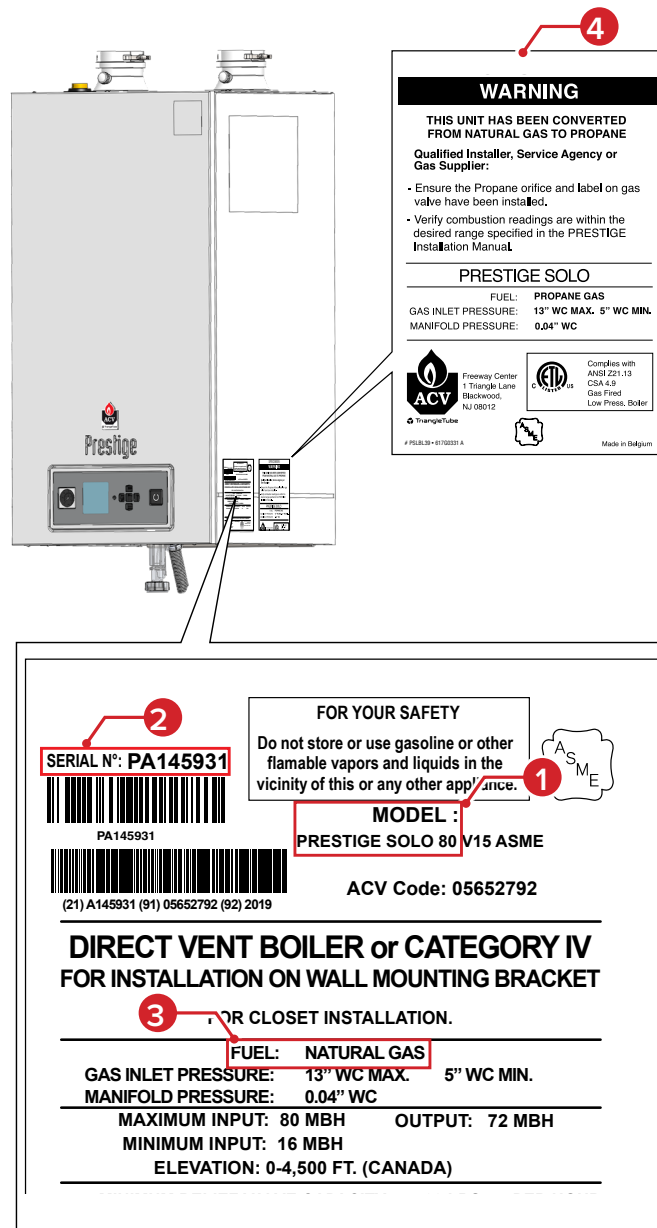

Fig. 2 - Location of Rating Label and Details on PA Boilers

HOW TO IDENTIFY THE BOILER TYPE AND MODEL

Report here the data that you managed to collect, by checking the corresponding boxes in the form below. Also indicate the gas type on which your boiler operates and the Serial Number (if you can get hold of the information).

If you have doubts or need help, please contact Triangle Tube. See the details at the bottom of the page.

1. If you managed to get the Serial Number of your appliance, you can contact Triangle Tube as indicated at the bottom of the page in order to fill in the relevant information and proceed with the 2025 voluntary recall.
2. Alternatively, you can contact your installer or service agency and ask them to proceed with the 2025 voluntary recall on your behalf.

MY BOILER IS A PRESTIGE :			Gas Type		Serial Number
Type	Model		Natural Gas	Propane	
PT	Solo	60			
		110			
		175			
		250			
		399			
		Excellence	110		
PA	Solo	80			
		110			
		155			
		175			
		250			
		299			
		399			
		Excellence	110		

On line portal via www.triangletube.com and hit the link PRODUCT RECALL INFORMATION or

Freephone **877-574-5036** from 8 a.m. to 5 p.m. ET Monday through Friday or

email at productrecall@triangletube.com.

